

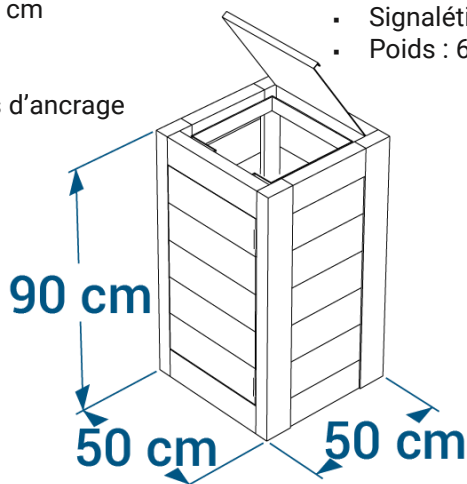

Corbeille CANOPÉE ref. 03.11

- Dimensions L.50 x P.50 x H.90 cm
- Ossature en plastique recyclé
- Porte frontale avec verrouillage à clé
- Porte et panneaux d'épaisseur 2,8 cm
- Contenance : porte-sac 130 L
- Trappe en aluminium
- Fixation par 2 équerres et goujons d'ancrage ref. EQ/GOUJ en option
- Poids : 60 kg



Option : Corbeille CANOPÉE en couleurs réf. 03.11.JRB

- Également disponible en coloris bleu, jaune, rouge

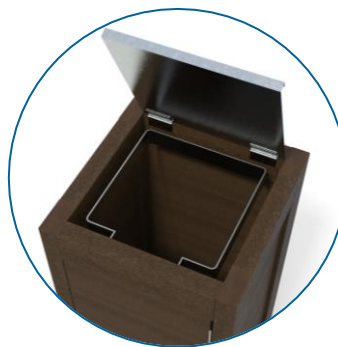

Porte-sac carré 130L



Version tri ref. 03.11.TRI

- 2 portes-sacs 60 L
- Signalétique incluse
- Poids : 61 kg



Coloris disponibles



Option :
Gamme
Color





Porte-sac
carré 130L

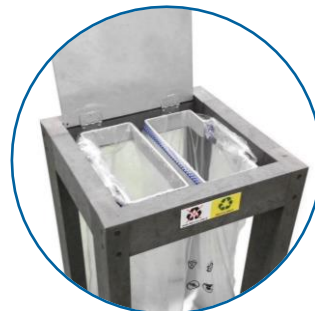

Coloris
disponibles



Corbeille CANOPÉE Vigipirate plexi

réf. 03.11.VP.PLEX

- Dimensions L.50 x P.50 x H.90 cm
- Ossature en plastique recyclé
- Porte frontale avec verrouillage à clé
- Porte et panneau arrière d'épaisseur 2,8 cm
- Côtés en plexiglas d'épaisseur 6 mm
- Contenance : porte-sac 130 L
- Trappe en aluminium
- Fixation par 2 équerres et goujons d'ancrage réf. EQ/GOUJ en option
- Poids : 57 kg

Version tri réf. 03.11.VP.PLEX.T

- 2 portes-sacs 60 L
- Signalétique incluse
- Poids total : 61 kg

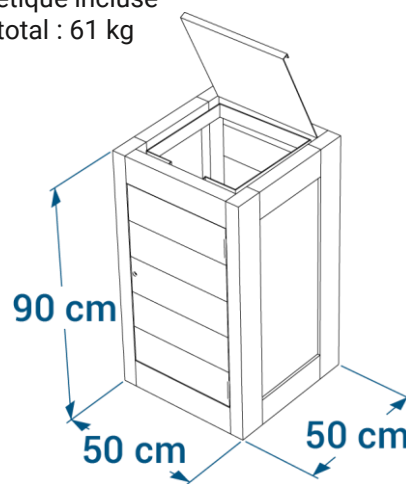

Option :
Gamme
Color



Option : Corbeille CANOPÉE Vigipirate plexi en couleurs réf. 03.11.VP.PLEX.JRB

et réf. 03.11.VP.PLEX.T.JRB

- Également disponible en coloris bleu, jaune, rouge

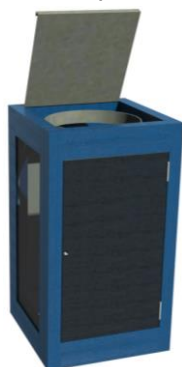



Coloris disponibles



Version tri réf. 03.15.VP.TRI

- 2 portes-sacs 60 L
- Signalétique incluse
- Poids total : 43 kg

Corbeille CANOPÉE Vigipirate avec protège-pluie réf. 03.15.VP

- Dimensions L.50 x P.50 x H.108,5 cm
- Ossature en plastique recyclé
- Contenance : porte-sac 130 L
- Fixation par 2 équerres et goujons d'ancrage réf. EQ/GOUJ en option
- Poids : 42 kg

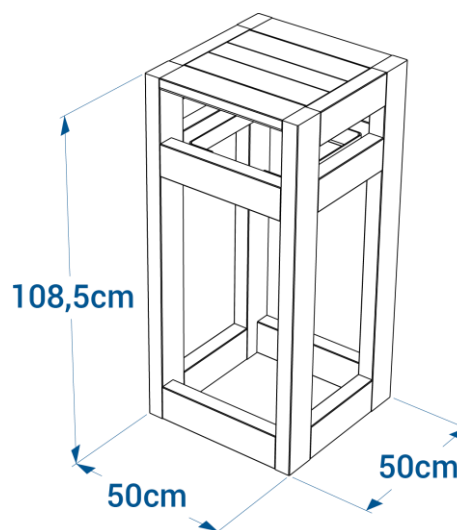

Option :
Gamme
Color



Option : Corbeille CANOPÉE Vigipirate avec protège-pluie en couleurs réf. 03.15.VP.JRB

- Également disponible en coloris bleu, jaune, rouge



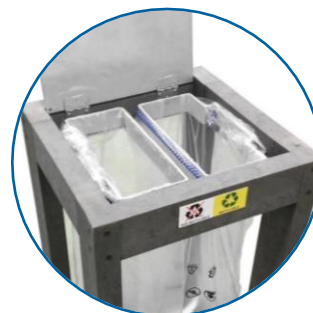

Version tri réf. 03.15.VP.PLEX.TRI

- 2 portes-sacs 60 L
- Signalétique incluse
- Poids total : 58 kg

Corbeille CANOPÉE Vigipirate plexi avec protège-pluie

réf. 03.15.VP.PLEX

- Dimensions L.50 x P.50 x H.108,5 cm
- Ossature en plastique recyclé
- Porte frontale avec verrouillage à clé
- Porte et panneau arrière d'épaisseur 2,8 cm
- Côtés en plexiglas d'épaisseur 6 mm
- Contenance : porte-sac 130 L
- Fixation par 2 équerres et goujons d'ancrage réf. EQ/GOUJ en option
- Poids : 57 kg

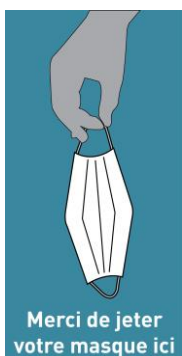
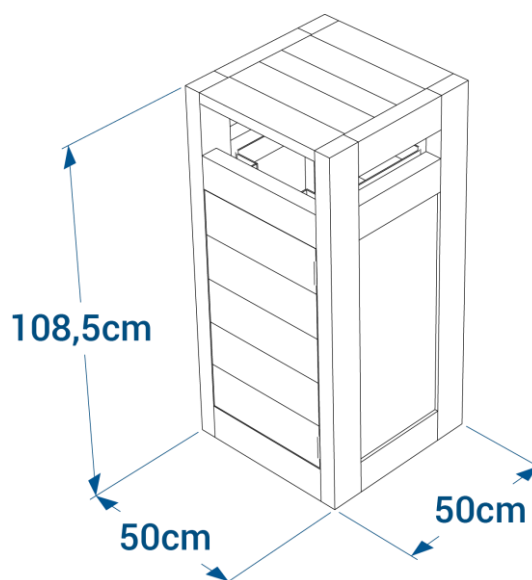

En option : plaque signalétique d'incitation à jeter les masques chirurgicaux

- À fixer sur la porte
- Plaque aluminium Dibon imprimée